



Hangers for the installation of Air Dielectric Cable® cables on different supporting profiles.
Cable Clamp and Extended Counterbed hot-galvanized steel
Screw: stainless steel.

FEATURES / BENEFITS



picture shows the 1L4 version for illustration purpose only

Technical features

GENERAL SPECIFICATIONS

Product Line		Coaxial Cable Accessories
Product Type		Hanger
Hanger Type		Anchor bar 18-22mm (0.71-0.87")
Transmission Line Type		HCA495
Cable Type		Air Dielectric

MECHANICAL SPECIFICATIONS

Cable Size		5
Material		Cable Clamp : hot-dip galvanized Extended Counterbed : hot-dip galvanized Screw: Stainless steel
Recommended / Maximum Clamp Spacing	m (ft)	1 / 2 (3.3 / 6.6)

TEMPERATURE SPECIFICATIONS

Operation Temperature	°C (°F)	-50 to 85 (-58 to 185)
Storage Temperature	°C (°F)	-50 to 85 (-58 to 185)

PACKAGING INFORMATION

Package Quantity		1
------------------	--	---

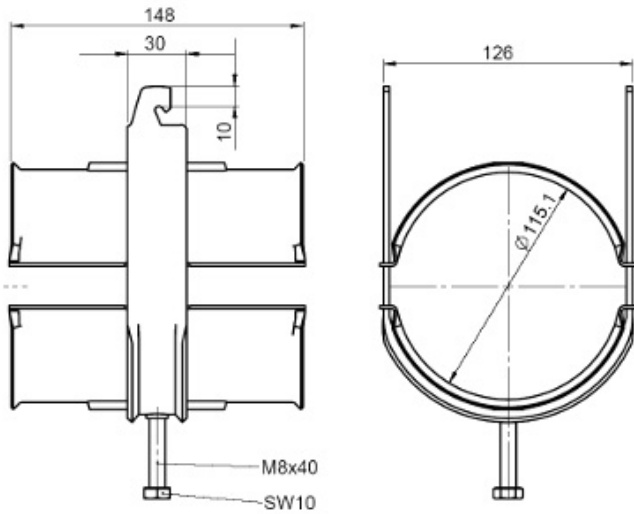

HCH Clamps available for different types of interfaces:

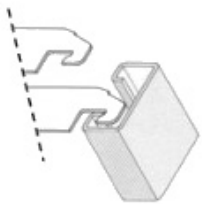

Type C
For anchor bar
(18-22mm slot)

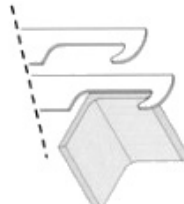

Type L
For angle iron
(in different sizes)

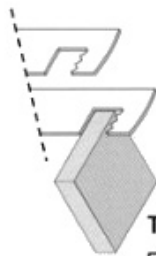

Type R
For flat iron
(6 – 12 mm)

External Document Links

Notes

Hangers for anchor bar 18-22 mm (0.71-0.87")