



OMNI FIT™ high performance connectors are designed for use with both CELLFLEX® (copper) and CELLFLEX® Lite (aluminum) cables. They are designed specifically to provide the highest quality connector-cable interface while simplifying and speeding up connector attachment. All RFS connectors are fully tested for mechanical and electrical compliance to industry specifications.

FEATURES / BENEFITS

- Cost effective two-piece design for safe and easy installation
- Robust mechanical design for low and consistent intermodulation performance i.e. keeps the mobile network performance up, reduces the number of dropped calls and avoids revenue losses
- Standard electrical performance for consistent and repeatable VSWR i.e. ensure network system performance
- Waterproof to IP 68 i.e. no downtime risk, secures revenue
- RoHS (EU) compliant i.e. can be used on a global basis



NF-SCF12-C03

[External Document Links](#)
[Installation Instruction](#)

[Notes](#)

Technical features

GENERAL SPECIFICATIONS

Transmission Line Type		Coaxial Cable
Cable Size		1/2
Cable Type		Foam Dielectric Superflexible
Model Series		SCF12-50 Series
Connector Interface		N
Connector Type		OMNI FIT™ Standard
Sealing Method		O-ring
Gender		Female

ELECTRICAL SPECIFICATIONS

Nominal Impedance, ohms	Ohm	50
3rd Order IM Product @ 2x20 Watts	dBc	-157 ; typical -160
Maximum Frequency	GHz	6.0
VSWR, Return Loss	VSWR (dB)	0 < f ≤ 1.0 GHz: 1.03 (36.6) 1.0 < f ≤ 2.7 GHz: 1.04 (34.1) 2.7 < f ≤ 3.7 GHz: 1.08 (28.3) 3.7 < f ≤ 5.0 GHz: 1.15 (23.1) 5.0 < f ≤ 6.0 GHz: 1.25 (19.1)



MECHANICAL SPECIFICATIONS

Plating Outer/Inner		Trimetal/Silver
Length	mm (in)	50.1 (2)
Outer Diameter	mm (in)	19.8 (0.78)
Inner Contact Attachment		Basket
Outer Contact Attachment		Rigidity impaction

ACCESSORIES

Wrench size front	mm (in)	16 (0.63)
Wrench size rear	mm (in)	18 (0.71)
Trimming Tool		TRIM-SET-S12-C02

TESTING AND ENVIRONMENTAL

Waterproof Level		IP68
------------------	--	------

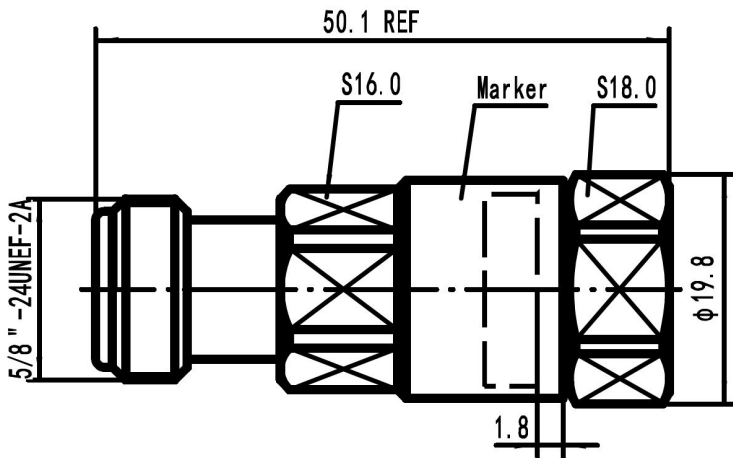

NF-SCF12-C03 Outline drawing